



## MHYC SSORC FARR 40 REGATTA

26<sup>TH</sup> & 27<sup>TH</sup> NOVEMBER 2016

### SAILING INSTRUCTIONS

### SAT 26 NOVEMBER



#### 1 RULES

- 1.1 The regatta shall be governed by the "rules" as defined in the 2013 - 2016 Racing Rules of Sailing (RRS), Yachting Australia Special Regulations Part 1 Category 4 and the Farr 40 Class Rules, except as any of these are changed by the sailing instructions.
- 1.2 RRS 44.2 is amended in that only one turn, including one tack and one gybe, is required except for infringements that occur within two boat lengths of a rounding mark
- 1.3 The race committee may carry out random checks for compliance of Rules as noted in 1.1 at any time during the regatta.
- 1.4 RRS 51 is amended by addition of the following sentence. "The maximum amount of drinkable liquid aboard each yacht shall not exceed 6 litres per person."
- 1.5 Where Farr 40 Class Rule 25.0 applies, the Class Administrator shall act as 'class representative'

#### 2 REGISTRATION AND WEIGH-IN

- 2.1 Registration shall take place from 0800 to 0900 on Saturday 26<sup>th</sup> November at Middle Harbour Yacht Club (MHYC). No weigh in is required for this regatta.

#### 3 NOTICES TO COMPETITORS

- 3.1 The official notice board is a notice board bearing that name outside the MHYC Sailing Office
- 3.2 VHF channel 72 shall be used as the Race Communications channel.
- 3.3 The Race Committee may broadcast race information before and during each race. Any such communication shall not be deemed as outside help. This Alters RRS 41.

#### 4 SIGNALS MADE ASHORE

- 4.1 Signals made ashore will be displayed on the flagstaff, located in front of the clubhouse.
- 4.2 Code flag "AP" with two sound signals (one when lowered) when displayed ashore means "Races not started are postponed". The Warning Signal shall not be made less than 30 minutes after the "AP" is lowered ashore. This Alters RRS Race Signals.

#### 5. CHANGES TO SAILING INSTRUCTIONS

- 5.1 Changes to the sailing instructions made ashore shall be posted before 0900 hrs on the day they shall take effect.
- 5.2 Changes to the Sailing Instructions made afloat shall be indicated by the display of Code Flag 3<sup>rd</sup> Substitute accompanied by two sound signals. The change may be communicated either orally or in writing.

## 6. SCHEDULE OF RACING

6.1 The regatta shall consist of a maximum of six (6) races.

Date	Event	Warning Signal
Saturday 26 <sup>th</sup> Nov	Up to 4 W/L races	1055 hrs
Sunday 27 <sup>th</sup> Nov.	See separate Sailing Instructions	1200hrs
Sunday 27 <sup>th</sup> Nov	Presentation of Prizes	<i>Asap after racing</i>

## 7 RACING AREA

8.1 The Racing Area will be on the waters of Port Jackson and the Tasman Sea and will be indicated by a Notice posted by 0900 hrs on the Official Notice Board each day.

## 9 MARKS

9.1 Mark 1 and the Gate marks will be orange buoys.

9.2 Mark 1a will be a yellow buoy

9.3 The start / finish mark will be a yellow buoy.

9.4 The change mark(s) as per SI 12, will be an orange buoy with a black band.

## 9. THE COURSE

9.1 The courses shall be windward / leeward.

9.2 A board displaying the course and approximate compass bearing from the mid-point of the starting line to Mark 1 shall be displayed by the Race Committee Boat.

9.3 Mark 1 shall be laid to windward of the start line. Mark 1a shall be laid to port of Mark 1.

9.4 The Gate may be laid approximately 50 metres to windward of the starting line. (Note: The Gate may be laid after the starting signal)

9.5 Yachts shall sail between the Gate marks from the direction of the previous mark and round either Gate mark. If only one Gate mark is set, the mark shall be rounded to port.

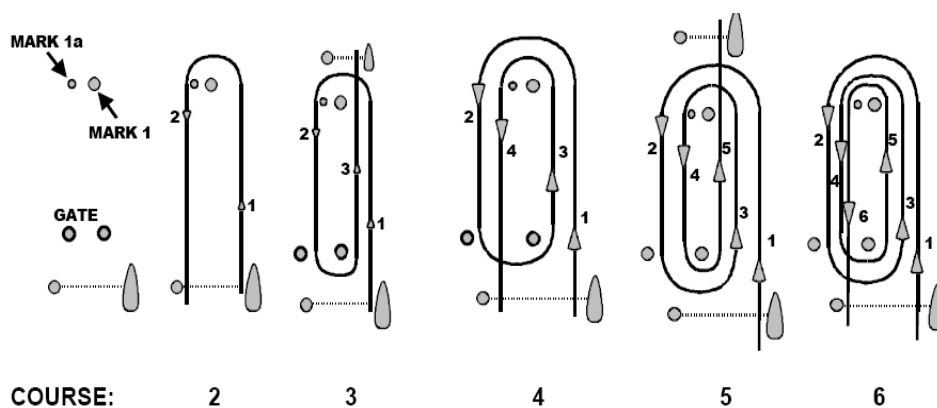

<b>COURSE SIGNAL</b>	<b>COURSE CONFIGURATION</b> All Marks rounded to PORT
<b>2</b>	Start – 1 – 1a – Finish (Downwind)
<b>3</b>	Start – 1 – 1a – Gate – Finish (Upwind)
<b>4</b>	Start – 1 – 1a – Gate – 1 – 1a – Finish (Downwind)
<b>5</b>	Start – 1 – 1a – Gate – 1 – 1a – Gate – Finish (Upwind)
<b>6</b>	Start – 1 – 1a – Gate – 1 – 1a – Gate – 1 – 1a – Finish (Downwind)

## **10 THE START**

10.1 The Class Flag shall be International Code Flag “W”.

10.2 Shall be between the Start / Finish Mark and the flagstaff displaying an orange flag on the Race Signal Vessel.

## **11 RECALLS**

11.1 In addition to RRS 29, the Race Committee MAY call yachts on channel 72.

## **12 CHANGING AND SHORTENING THE COURSE**

12.1 When changing the position of the next mark, the race committee shall lay a change mark(s). Any subsequent marks may be relocated to maintain the original course configuration. Further changes of that mark shall revert to the original mark(s).

## **13 FINISH LINE**

13.1 Shall be between the Start / Finish mark and the flagstaff displaying an orange flag on the Race Signal Vessel. The Start / Finish mark may be relocated closer to the Race Signal Vessel after the start.

## **14 TIME LIMIT**

14.1 The time limit for all races shall be 2 hours from the start, or within twenty five minutes of the first boat to finish, whichever is the earliest.

14.2 Yachts not finishing within the time limit shall be scored points equal to the number of boats finishing within the time limit plus two points, but no more points than the number of starters. This changes RRS 35, A4.2 and A5.

## **15 PROTESTS**

15.1 Submission of Protests:

Protests in accordance with RRS 61 shall be delivered to the MHYC Sailing Office within 1.5 hours after the finish time of the last boat. (in the last race of the day when multiple races are conducted).

15.2 Hearing of Protests:

Protests may be heard in approximately the order of receipt. In accordance with RRS 63.2, a notice of Hearing will be posted on the official notice board within ten minutes after the end of the protest time limit.

15.3 Reopening a Hearing:

RRS 66 is changed by adding: “On the last day of racing, a party to the hearing may ask for a reopening no later than half an hour after being informed of the decision.”

15.4 In accordance with RRS 64.1(a) the protest committee may make any determination it decides is equitable for the fleet.

## **16 ARBITRATION**

16.1 At the option of the protest committee a short arbitration hearing may be heard prior to a protest hearing (affecting Rule 63). After the written protest form is properly lodged, one representative from each boat shall meet with the arbitrator, no witnesses shall be allowed. Protests not resolved by arbitration shall be lodged with the Protest Committee.

16.2 Boats that accept fault at an arbitration hearing shall be penalised by having her race score increased by a 40% scoring penalty calculated as stated in rule 44.3(c) but not more than a DSQ. All other boats scores shall remain the same. Once accepted by all parties, this decision is not subject to reopening or appeal and the protest shall be withdrawn. This alters RRS 60.1, 62 and 66.

16.3 The arbitrator may be a member of any subsequent Protest Committee.

## **17 SCORING**

17.1 The MHYC Farr 40 Regatta will consist of a maximum of six (6) races. The minimum races to constitute a series will be two (2).

17.2 The Low Point scoring system, Appendix A of the RRS shall apply except all races shall count for total points.

## **18 PRIZES AND TROPHIES**

18.1 Prizes shall be awarded to each yacht placing first, second and third in the regatta. Prizes shall also be awarded to each race winner and daily to the Boat of the Day.



## SAILING INSTRUCTIONS MHYC SSORC FARR 40 REGATTA SUNDAY 27 NOVEMBER

*(Addendum to Sailing Instructions for Saturday 26 November)*

### RACE 5 & 6 (WINDWARD / LEEWARD, TRIANGULAR & SOP COURSES)

#### 1.0 RACING AREA

- 1.1 The racing area for Race 5 and Race 6 on Sunday 27 November will be the Manly Circle or Macquarie Circle off Sydney and will be indicated by a Notice posted by 0830 hrs on the Official Notice Board.

#### 2.0 FINISH AREA

- 2.1 The Finish Line for Race 6 will be inside Port Jackson, in the vicinity of Watsons Bay.

#### 3.0 SCHEDULE OF RACES

- 3.1 Two (2) races are scheduled for Day 2. The Race Committee may change this schedule at any time.

##### Race 5: Sunday 27 November - (Windward/Leeward or Triangle)

DATE	CLASS(S)	EVENT	TIME	LOCATION
Sun 27 Nov	Division 1 (IRC/ORCi/PHS)	Warning Signal	1155 hrs	As per SI 7.2
	FARR 40 CLASS	Warning Signal	1200HRS	As per SI 1.1
	Division 2 (IRC/ORCi/PHS)	Warning Signal	1205 hrs	As per SI 7.2

##### Race 6: Sunday 27 November - (Short Ocean Race)

DATE	CLASS(S)	EVENT	TIME	LOCATION
Sun 27 Nov	Division 1 (IRC/ORCi/PHS)	Warning Signal	ASAP after preceding race	Tasman Sea & Sydney Harbour
	FARR 40 CLASS	Warning Signal	ASAP after preceding race	Tasman Sea & Sydney Harbour
	Division 2 (IRC/ORCi/PHS)	Warning Signal	ASAP after preceding race	Tasman Sea & Sydney Harbour

- 3.2 On Sunday 27 November no Warning Signal shall be made after 1530 hours.

#### 4.0 DESCRIPTION OF COURSES

- 4.1 The course to be sailed for each class will be signalled by a Numeral Board displayed from the Committee Vessel at or prior to the Warning Signal. The course to be sailed may also be broadcast on the designated course VHF Channel.
- 4.2 A board displaying the approximate compass bearing from the Committee Vessel to Mark 1 and Mark 4 will be displayed from the Committee Vessel.
- 4.3 Mark 1 and Mark 4 will be laid to windward of the start line.

- 4.4 The Gate will be laid approximately 50 metres to windward of the start line. If only one Gate mark is laid, boats shall round that mark to port. (Note: The Gate may be laid after the starting signal).
- 4.5 All Marks to PORT except the Gate. Either Gate mark may be rounded to port or to starboard AFTER passing through the Gate from the direction of the last mark.
- 4.6 For a change of course or length of one leg, the Race Committee will move the original mark (or marks or finish line) or will lay a new mark (or marks) identical to the original at the new position. Any subsequent marks may be relocated to maintain the original course configuration.
- 4.7 The triangle formed by Marks 1, 2 & 3 is a right angled triangle with the angle at mark 2 approximately 90 degrees.

**5.0 DESCRIPTION OF MARKS**

<b>MARK</b>	<b>DESCRIPTION</b>
Start / Finish Mark	Yellow inflatable buoy
Mark 1	Yellow inflatable buoy
Mark 2	Orange inflatable buoy
Mark 3	Orange inflatable buoy
Mark 4	Orange inflatable buoy
Gate Mark(s)	Orange inflatable buoy
Change Mark(s)	As above in its 'new position'

6 COURSE DIAGRAMS

WINDWARD / LEEWARD COURSES

COURSE SIGNAL	COURSE CONFIGURATION
1	Start – 1 – Finish
2	Start – 1 – Gate – 1 – Finish
3	Start – 1 – Gate – 1 – Gate – 1 – Finish
4	Start – 4 – Finish
5	Start – 4 – Gate – 4 – Finish
6	Start – 4 – Gate – 4 – Gate – 4 – Finish

TRIANGULAR COURSES

COURSE SIGNAL	COURSE CONFIGURATION
7	Start – 1 – 2 – 3 – 1 – Finish
8	Start – 1 – 2 – 3 – 1 – 3 – 1 – Finish
9	Start – 1 – 2 – 3 – 1 – 2 – Finish
10	Start – 4 – 2 – 3 – 4 – Finish
11	Start – 4 – 2 – 3 – 4 – 3 – 4 – Finish
12	Start – 4 – 2 – 3 – 4 – 2 – Finish

NOTE: The Finish Line for Race 6 will be inside Port Jackson, in the vicinity of Watsons Bay

